

# Brief Operating Instructions Loop-powered display unit

with HART® communication  
ORIA15

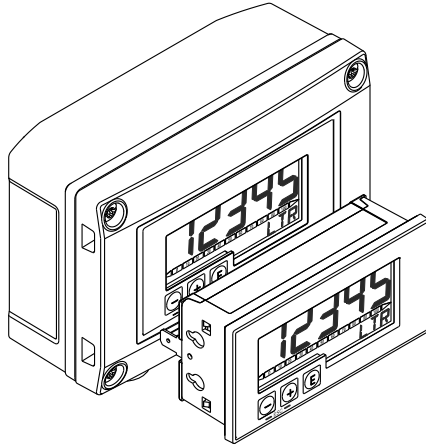

These instructions are Brief Operating Instructions; they do not replace the Operating Instructions included in the scope of supply.

For detailed information, refer to the Operating Instructions and other documentation on the CD-ROM provided.



# Table of contents



- 1 Document information ..... 2**
  - 1.1 Document conventions ..... 2
  - 1.2 Registered trademarks ..... 5
- 2 Safety instructions ..... 5**
  - 2.1 Requirements for the personnel ..... 5
  - 2.2 Designated use ..... 5
  - 2.3 Workplace safety ..... 6
  - 2.4 Operational safety ..... 6
  - 2.5 Product safety ..... 6
- 3 Identification ..... 6**
  - 3.1 Nameplate ..... 6
  - 3.2 Scope of delivery ..... 7
  - 3.3 Certificates and approvals ..... 7
  - 3.4 HART® protocol certification ..... 8
- 4 Installation ..... 8**
  - 4.1 Incoming acceptance, transport, storage ..... 8
  - 4.2 Installation conditions ..... 8
  - 4.3 Installation instructions ..... 9
  - 4.4 Post-installation check ..... 13
- 5 Wiring ..... 13**
  - 5.1 Quick wiring guide ..... 14
  - 5.2 Connection in 4 to 20 mA mode ..... 15
  - 5.3 Connection in HART mode ..... 16
  - 5.4 Inserting the cable, field housing ..... 22
  - 5.5 Shielding and grounding ..... 22
  - 5.6 Connecting to functional grounding ..... 23
  - 5.7 Degree of protection ..... 24
  - 5.8 Post-connection check ..... 25
- 6 Operation ..... 25**
  - 6.1 Operating functions ..... 26

## 1 Document information







### 1.1 Document conventions

#### 1.1.1 Safety symbols



Symbol	Meaning
 <small>A0011189-EN</small>	<b>DANGER!</b> This symbol alerts you to a dangerous situation. Failure to avoid this situation will result in serious or fatal injury.
 <small>A0011190-EN</small>	<b>WARNING!</b> This symbol alerts you to a dangerous situation. Failure to avoid this situation can result in serious or fatal injury.







Symbol	Meaning
 <small>A0011191-EN</small>	<b>CAUTION!</b> This symbol alerts you to a dangerous situation. Failure to avoid this situation can result in minor or medium injury.
 <small>A0011192-EN</small>	<b>NOTICE!</b> This symbol contains information on procedures and other facts which do not result in personal injury.

### 1.1.2 Electrical symbols





Symbol	Meaning
 <small>A0011197</small>	<b>Direct current</b> A terminal to which DC voltage is applied or through which direct current flows.
 <small>A0011198</small>	<b>Alternating current</b> A terminal to which alternating voltage is applied or through which alternating current flows.
 <small>A0017381</small>	<b>Direct current and alternating current</b> <ul style="list-style-type: none"> <li>▪ A terminal to which alternating voltage or DC voltage is applied.</li> <li>▪ A terminal through which alternating current or direct current flows.</li> </ul>
 <small>A0011200</small>	<b>Ground connection</b> A grounded terminal which, as far as the operator is concerned, is grounded via a grounding system.
 <small>A0011199</small>	<b>Protective ground connection</b> A terminal which must be connected to ground prior to establishing any other connections.
 <small>A0011201</small>	<b>Equipotential connection</b> A connection that has to be connected to the plant grounding system: This may be a potential equalization line or a star grounding system depending on national or company codes of practice.
 <small>A0012751</small>	<b>ESD - Electrostatic discharge</b> Protect the terminals against electrostatic discharge. Failure to comply with this instruction can result in the destruction of parts or malfunction of the electronics.

### 1.1.3 Symbols for certain types of information



Symbol	Meaning
 <small>A0011182</small>	<b>Allowed</b> Indicates procedures, processes or actions that are allowed.
 <small>A0011183</small>	<b>Preferred</b> Indicates procedures, processes or actions that are preferred.
 <small>A0011184</small>	<b>Forbidden</b> Indicates procedures, processes or actions that are forbidden.



Symbol	Meaning
 A0011193	<b>Tip</b> Indicates additional information.
 A0011194	<b>Reference to documentation</b> Refers to the corresponding device documentation.
 A0011195	<b>Reference to page</b> Refers to the corresponding page number.
 A0011196	<b>Reference to graphic</b> Refers to the corresponding graphic number and page number.
	<b>Series of steps</b>
	<b>Result of a sequence of actions</b>

### 1.1.4 Symbols in graphics

Symbol	Meaning
<b>1, 2, 3,...</b>	Item numbers
	Series of steps
<b>A, B, C, ...</b>	Views
<b>A-A, B-B, C-C, ...</b>	Sections
 A0013441	Flow direction
 A0011187	<b>Hazardous area</b> Indicates a hazardous area.
 A0011188	<b>Safe area (non-hazardous area)</b> Indicates a non-hazardous area.

### 1.1.5 Tool symbols

Symbol	Meaning
 A0011220	Flat blade screwdriver
 A0011221	Allen key

Symbol	Meaning
 A0011222	Open-ended wrench
 A0013442	Torx screwdriver

## 1.2 Registered trademarks

### HART®

Registered trademark of the HART® Communication Foundation

## 2 Safety instructions

### 2.1 Requirements for the personnel

The personnel must fulfill the following requirements for its tasks:

- ▶ Trained, qualified specialists must have a relevant qualification for this specific function and task
- ▶ Are authorized by the plant owner/operator
- ▶ Are familiar with federal/national regulations
- ▶ Before beginning work, the specialist staff must have read and understood the instructions in the Operating Instructions and supplementary documentation as well as in the certificates (depending on the application)
- ▶ Following instructions and basic conditions

### 2.2 Designated use

The process display unit displays analog process variables or HART® process variables on its screen.

4 to 20 mA The device is powered via the current loop and does not require an additional power supply.

- The manufacturer accepts no liability for damages resulting from incorrect use or use other than that designated. It is not permitted to convert or modify the device in any way.
- Panel-mounted device  
The device is designed for installation in a panel and must only be operated in an installed state.
- Field device:  
The device is designed for installation in the field.
- The device may only be operated under the permitted ambient conditions .

## 2.3 Workplace safety

For work on and with the device:

- ▶ Wear the required personal protective equipment according to federal/national regulations.

## 2.4 Operational safety

Risk of injury!

- ▶ Operate the device in proper technical condition and fail-safe condition only.
- ▶ The operator is responsible for interference-free operation of the device.

### Conversions to the device

Unauthorized modifications to the device are not permitted and can lead to unforeseeable dangers.

- ▶ If modifications are still required, consult with the supplier.

### Repair

To ensure continued operational safety and reliability,

- ▶ Carry out repairs on the device only if they are expressly permitted.
- ▶ Observe federal/national regulations pertaining to repair of an electrical device.
- ▶ Use only original spare parts and accessories.

### Hazardous area

To eliminate the risk of danger to persons or the facility when the device is used in the approval-related area (e.g. explosion protection, pressure equipment safety):

- ▶ Check the nameplate to verify if the device ordered can be put to its intended use in the approval-related area.
- ▶ Observe the specifications in the separate supplementary documentation that is an integral part of these Instructions.

## 2.5 Product safety

This measuring device is designed in accordance with good engineering practice to meet state-of-the-art safety requirements, has been tested, and left the factory in a condition in which it is safe to operate.

It meets general safety standards and legal requirements. It also complies with the EC directives listed in the device-specific EC Declaration of Conformity. The manufacturer confirms this by affixing the CE mark to the device.

# 3 Identification

## 3.1 Nameplate

The nameplate is located on the right-hand side of the housing in the case of the field device, and on the rear of the housing in the case of the panel-mounted device.

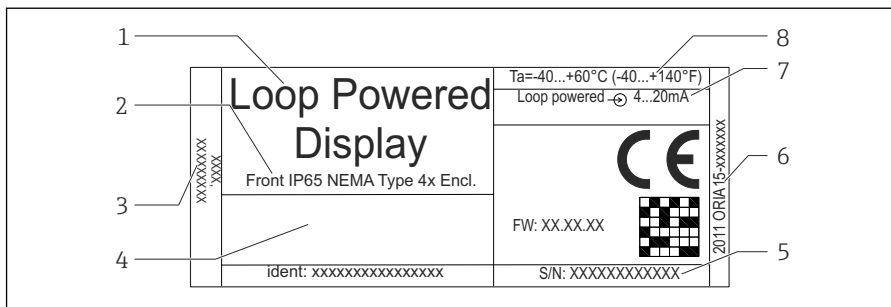

A0019058

- |   |                              |   |                             |
|---|------------------------------|---|-----------------------------|
| 1 | Device designation           | 5 | Serial number of the device |
| 2 | Housing degree of protection | 6 | Order code of the device    |
| 3 | Manufacturer's address       | 7 | Input signal                |
| 4 | Approvals (optional)         | 8 | Ambient temperature range   |

### 3.2 Scope of delivery

The scope of delivery of the device comprises:

- Panel-mounted device
  - Process display unit
  - Brief Operating Instructions
  - Operating Instructions on CD-ROM
  - Ex Safety Instructions (optional)
  - Fastening fixtures
  - HART® communication resistance module (optional)
- Field device
  - Process display unit
  - Brief Operating Instructions
  - Operating Instructions on CD-ROM
  - Ex Safety Instructions (optional)
  - Fastening fixtures for wall/pipe mounting (optional)
  - HART® communication resistance module (optional)
  - Weather protection cover (optional)

### 3.3 Certificates and approvals

An overview of all available approvals is provided in the "Technical data" section in the relevant Operating Instructions.

#### CE mark, Declaration of Conformity

The device is designed to meet state-of-the-art safety requirements, has been tested, and left the factory in a condition in which it is safe to operate. The device complies with the applicable standards and regulations in accordance with EN 61010-1 "Safety requirements for electrical equipment for measurement, control and laboratory use".

The device described in these Operating Instructions therefore complies with the statutory requirements of the EU Directives. The manufacturer confirms that the device has been successfully tested by applying the CE mark.

### 3.4 HART® protocol certification

The process display unit is registered by the HART® Communication Foundation. The device fulfills the requirements of HCF Specification, Revision 7.1. This version is downwards compatible with all sensors/actuators with HART® versions  $\geq 5.0$ .

## 4 Installation

### 4.1 Incoming acceptance, transport, storage

Compliance with the permitted environmental and storage conditions is mandatory. Precise specifications for this are provided in the "Technical data" in the relevant Operating Instructions.

#### 4.1.1 Incoming acceptance

On receipt of the goods, check the following points:

- Is the packaging or the content damaged?
- Is the delivery complete? Compare the scope of delivery against the information on your order form.

#### 4.1.2 Transport and storage

Please note the following:

- Pack the device so that it is protected against impact for storage and transport. The original packaging provides optimum protection.
- The permitted storage temperature is  $-40$  to  $+85$  °C ( $-40$  to  $+185$  °F); it is possible to store the device at borderline temperatures for a limited period (48 hours maximum).

### 4.2 Installation conditions



At temperatures below  $-25$  °C ( $-13$  °F) the readability of the display can no longer be guaranteed.

#### 4.2.1 Display unit in the panel-mount housing

Permitted ambient temperature range  $-40$  to  $60$  °C ( $-40$  to  $140$  °F), horizontal orientation. IP65 protection at front, IP20 at rear

See "Technical data" section in the relevant Operating Instructions.

#### 4.2.2 Display unit in the field housing

Permitted ambient temperature range  $-40$  to  $60$  °C ( $-40$  to  $140$  °F). IP66 protection, NEMA 4x.



See "Technical data" section in the relevant Operating Instructions.

## 4.3 Installation instructions

For the dimensions of the device, see the "Technical data" section in the relevant Operating Instructions.

### 4.3.1 Panel housing

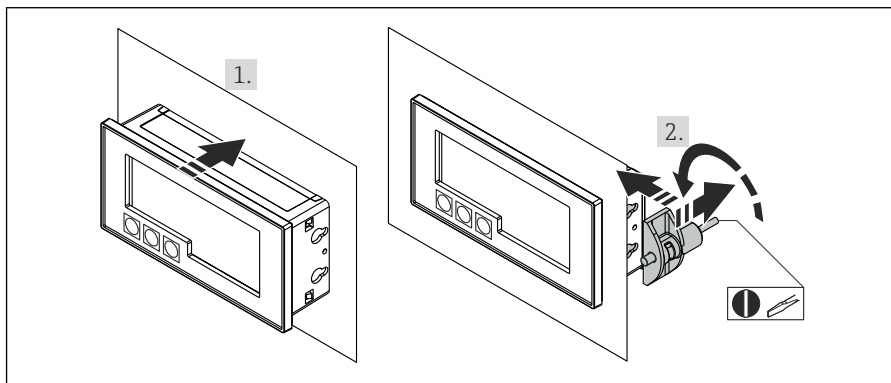

A0017762

#### 1 Installation instructions for the panel housing

Installation in a panel with a panel cutout 92x45 mm (3.62x1.77 in), max. panel thickness 13 mm (0.51 in).

1. Slot the device into the panel cutout from the front.
2. Fit the mounting clips on the side of the housing and tighten the threaded rods.

### 4.3.2 Field housing

#### Pipe mounting (with optional mounting kit)

The device can be mounted on a pipe with a diameter of up to 50.8 mm (2 in) with the mounting kit (optionally available).

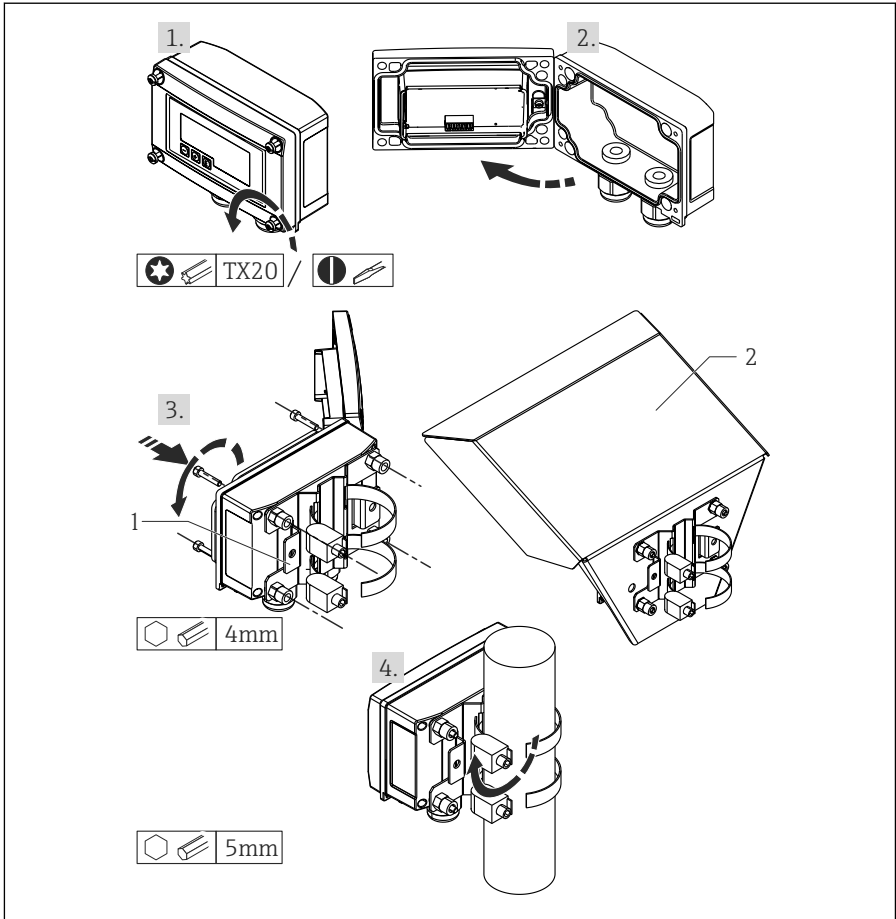

A0017789

**2** *Mounting the process display unit on a pipe*

- 1 *Mounting plate for pipe/wall mounting*
- 2 *Weather protection cover (optional)*

1. Release the 4 housing screws
2. Open the housing
3. Secure the mounting plate to the rear of the device with 4 screws supplied. The optional weather protection cover can be secured between the device and the mounting plate.
4. Guide the two gripper clamps through the mounting plate, fit them around the pipe and tighten.

## Wall mounting

With optionally available mounting kit.

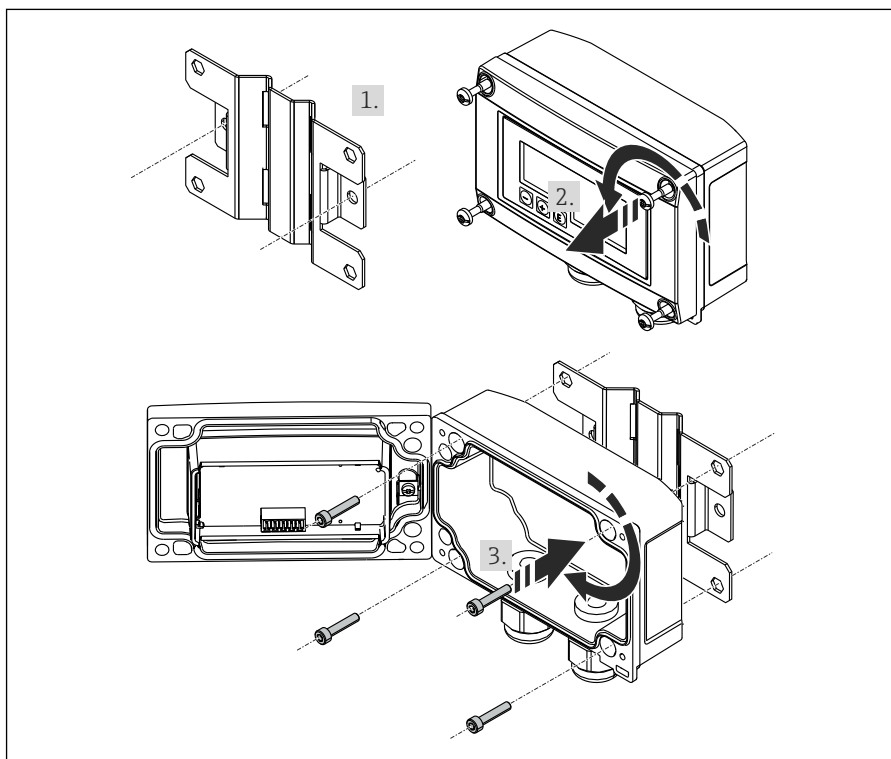

A0017803

### 3 Mounting the process display unit on a wall

1. Use the mounting plate as a stencil for 2 6 mm (0.24 in) bore holes, 82 mm (3.23 in) apart, and secure the plate on the wall with 2 screws (not supplied).
2. Open the housing.
3. Secure the display unit on the mounting plate with the 4 screws supplied.
4. Close the cover and tighten the screws.

### Without a mounting kit.

1. Open the housing.
2. Use the device as a stencil for 4 6 mm (0.24 in) bore holes, 99 mm (3.9 in) apart on the horizontal plane, 66 mm (2.6 in) apart on the vertical plane.

3. Secure the display unit on the wall with 4 screws.
4. Close the cover and tighten the housing screws.

### 4.3.3 Mounting the optional HART® communication resistance module

#### Panel housing

The HART® communication resistance module is available as an accessory, see section Accessories in the relevant Operating instructions.

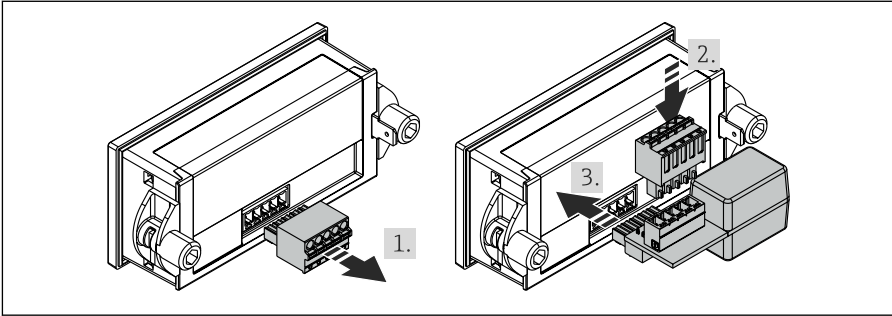

A0020785

#### 4 Mounting the optional HART® communication resistance module

1. Unplug the pluggable terminal block.
2. Plug terminal block into the suitable plug-in position on the HART® communication resistance module.
3. Plug the HART® communication resistance module into the plug-in position on the housing.

#### Field housing

The HART® communication resistance module is available as an accessory, see section Accessories in the relevant Operating instructions.

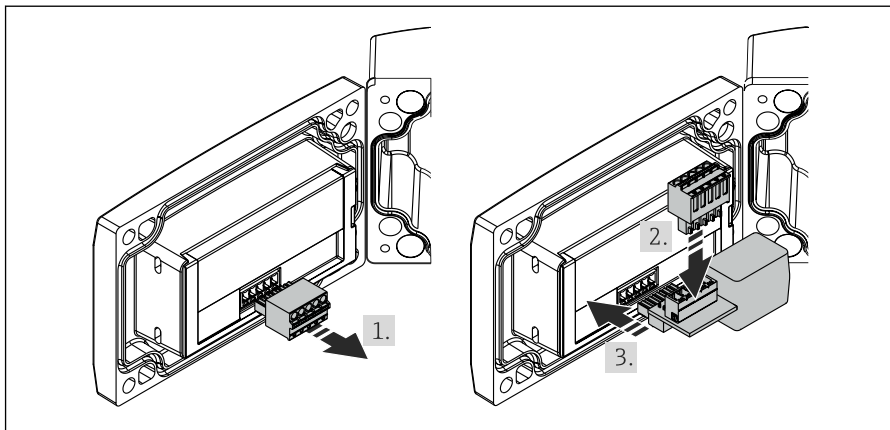

A002084

#### 5 Mounting the optional HART® communication resistance module

1. Unplug the pluggable terminal block.
2. Plug terminal block into the suitable plug-in position on the HART® communication resistance module.
3. Plug the HART® communication resistance module into the plug-in position in the housing.

## 4.4 Post-installation check

### 4.4.1 Display unit in the panel-mount housing

- Is the seal undamaged?
- Are the mounting clips securely fastened on the housing of the device?
- Are the threaded rods properly tightened?
- Is the device located in the center of the panel cutout?

### 4.4.2 Display unit in the field housing

- Is the seal undamaged?
- Is the housing firmly screwed to the mounting plate?
- Is the mounting bracket firmly secured on the wall/pipe?
- Are the housing screws firmly tightened?

## 5 Wiring

### **⚠ WARNING**

**Danger! Electric voltage!**

- ▶ The entire connection of the device must take place while the device is de-energized.

Only certified devices (optionally available) may be connected in the hazardous area  
 ▶ Observe corresponding notes and wiring diagrams in the Ex-specific supplement to these Operating Instructions. Your supplier is available for assistance if required.

**NOTICE**

**SELV / Class 2 device**

- ▶ The device may only be powered by a power unit with an energy-limited circuit in accordance with IEC 61010-1: 'SELV or Class 2 circuit'.

Device destroyed if current too high

- ▶ Do not operate the device at a voltage source without a current limiter. Instead, operate the device only in the current loop with a transmitter.

▪ **Panel housing:**

The terminals are located on the rear of the housing.

▪ **Field housing:**

The terminals are located inside the housing. The device has two M16 cable entries. The housing must be opened for wiring purposes.

**Operation of the spring terminals**

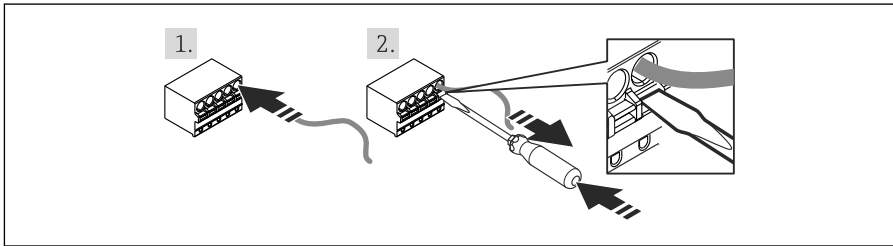

A0020848

6 Operation of the spring terminals

1. When using rigid cable with ferrule, just plug the cable into the terminal. No tools required. With flexible wire the spring mechanism of the terminal must be operated as shown in step 2.
2. In order to loosen the cable, push the spring mechanism in completely using a screwdriver or other suitable tool and pull out the cable.

**5.1 Quick wiring guide**

Terminal	Description
+	Positive connection, current measurement
-	Negative connection, current measurement (without backlighting)
LED	Negative connection, current measurement (with backlighting)

Terminal	Description
	Auxiliary terminals (electrically connected internally)
	Functional grounding: <ul style="list-style-type: none"> <li>■ Panel-mounted device: Terminal on the rear of the housing</li> <li>■ Field device: Terminal in the housing</li> </ul>

## 5.2 Connection in 4 to 20 mA mode

The following diagrams show how the process display unit is connected in 4 to 20 mA mode.

	Connection without backlighting	Connection with backlighting
Connection with transmitter power supply and transmitter	<p style="text-align: right;">A0017704</p> <p>1 Transmitter power supply</p>	<p style="text-align: right;">A0017705</p> <p>1 Transmitter power supply</p>
Connection with transmitter power supply and transmitter using the auxiliary terminal	<p style="text-align: right;">A0017706</p> <p>1 Transmitter power supply</p>	<p style="text-align: right;">A0017707</p> <p>1 Transmitter power supply</p>

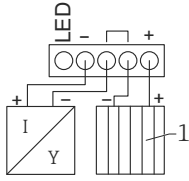
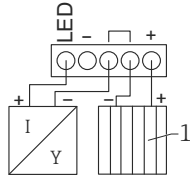
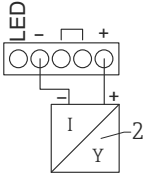
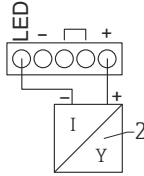
	Connection without backlighting	Connection with backlighting
Connection with PLC and transmitter	 <p style="text-align: right;">A0019720</p> <p>1 PLC</p>	 <p style="text-align: right;">A0019721</p> <p>1 PLC</p>
Connection without transmitter power supply directly in the 4 to 20 mA circuit	 <p style="text-align: right;">A0017708</p> <p>2 4 to 20 mA power source</p>	 <p style="text-align: right;">A0017709</p> <p>2 4 to 20 mA power source</p>

### 5.3 Connection in HART mode

The following diagrams show how the process display unit is connected in HART mode.

#### 5.3.1 HART® connection

**NOTICE**

**Undefined behavior due to incorrect wiring of an actuator**

- ▶ When installing the process display unit together with an actuator, the Operating Instructions for the actuator must be followed!

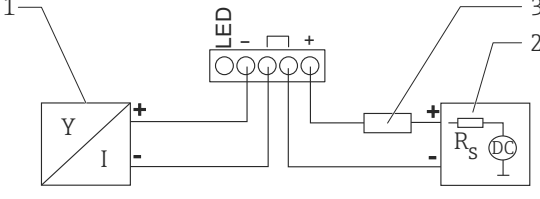
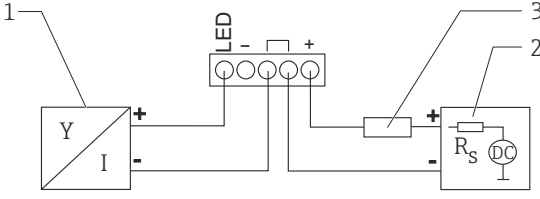
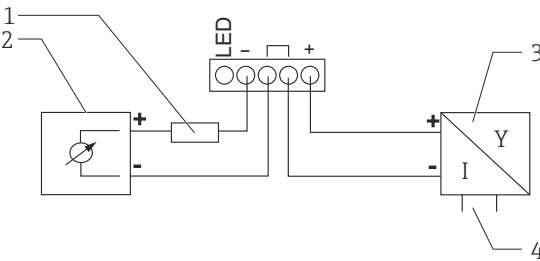

**i** The HART<sup>®</sup> communication resistance of 230 Ω in the signal line is always necessary in the case of a low-impedance power supply. It must be installed between the power supply and the display unit.

Circuit diagram / Description	
<p>2-wire sensor with process display unit and loop power supply, without backlighting</p>	 <p>1 Sensor 2 Power supply 3 HART<sup>®</sup> resistance</p> <p style="text-align: right;">A0019567</p>
<p>2-wire sensor with process display unit and loop power supply, with backlighting</p>	 <p>1 Sensor 2 Power supply 3 HART<sup>®</sup> resistance</p> <p style="text-align: right;">A0019568</p>
<p>4-wire sensor with process display unit and loop power supply, without backlighting</p>	 <p>1 HART<sup>®</sup> resistance 2 Current meter (optional) 3 Sensor 4 Power supply 4-wire device</p> <p style="text-align: right;">A0019570</p>

Circuit diagram / Description	
<p>4-wire sensor with process display unit and loop power supply, with backlighting</p>	<p>1 HART® resistance                  2 Current meter (optional)                  3 Sensor                  4 Power supply 4-wire device</p> <p style="text-align: right;">A0019571</p>
<p>Current output with process display unit and actuator (e.g. actuator valve), without backlighting</p>	<p>1 Actuator                  2 Power supply 4-wire device                  3 Current output</p> <p style="text-align: right;">A0019573</p>
<p>Current output with process display unit and actuator (e.g. actuator valve), with backlighting</p>	<p>1 Actuator                  2 Power supply 4-wire device                  3 Current output</p> <p style="text-align: right;">A0019574</p>

Circuit diagram / Description	
<p>Multi-drop 2-wire sensors with process display unit and loop power supply</p>	<p>1 Sensors 2 Power supply 3 HART® resistance</p>
<p>Multi-drop 2-wire sensors with process display unit and loop power supply, with backlighting</p>	<p>1 Sensors 2 Power supply 3 HART® resistance</p>

A0019575

A0019722

### Optional HART® communication resistance module

A HART® communication resistance module is available as an accessory, see section Accessories in the relevant Operating Instructions.

Mounting of the HART® communication resistance module see section Installation instructions (→ 12)

Wiring

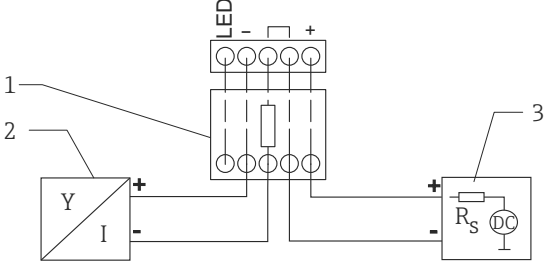
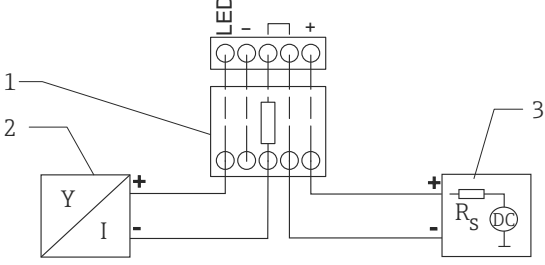
	Circuit diagram / Description
<p>2-wire sensor with process display unit and loop power supply, without backlighting</p>	 <p>1 HART® communication resistance module                  2 Sensor                  3 Power supply</p> <p style="text-align: right;">A0020839</p>
<p>2-wire sensor with process display unit and loop power supply, with backlighting</p>	 <p>1 HART® communication resistance module                  2 Sensor                  3 Power supply</p> <p style="text-align: right;">A0020840</p>

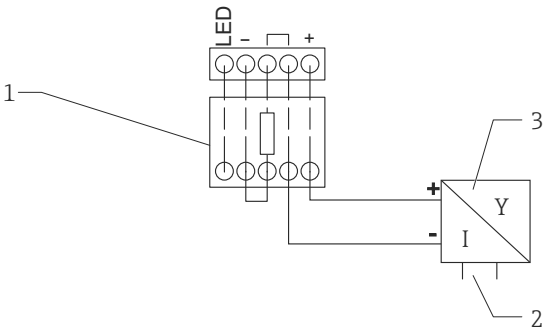
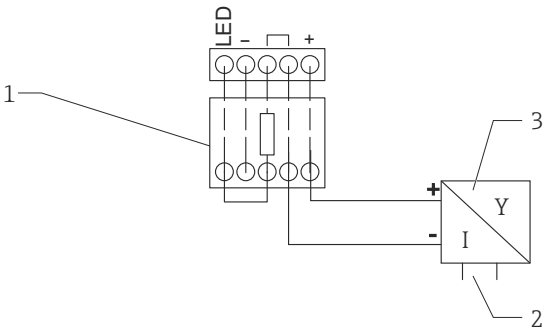
Circuit diagram / Description	
<p>4-wire sensor with process display unit and loop power supply, without backlighting</p>	 <p>1 HART® communication resistance module 2 Power supply of 4-wire device 3 Sensor</p> <p style="text-align: right;">A0020837</p>
<p>4-wire sensor with process display unit and loop power supply, with backlighting</p>	 <p>1 HART® communication resistance module 2 Power supply of 4-wire device 3 Sensor</p> <p style="text-align: right;">A0020838</p>

## 5.4 Inserting the cable, field housing

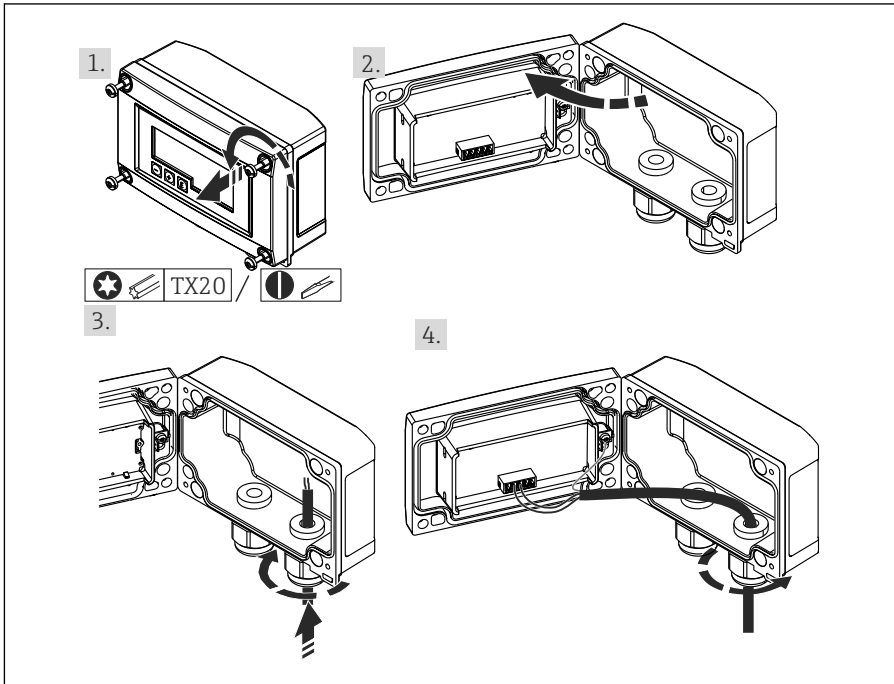

A0017830

7 Inserting the cable, field housing

Inserting the cable, field housing, connection without transmitter power supply (example)

1. Release the housing screws
2. Open the housing
3. Open the cable gland (M16) and insert the cable.
4. Connect the cable incl. functional grounding and close the cable gland

## 5.5 Shielding and grounding

Optimum electromagnetic compatibility (EMC) can only be guaranteed if the system components and, in particular, the lines are shielded and the shield forms as complete a cover as possible.

HART® communication allows three different types of shielding:

- Shielding at both ends
- Shielding at one end on the feed side with capacitance termination at the field device
- Shielding at one end on the feed side

The best results with regard to EMC are achieved in most cases with one-sided shielding on the feed side (without capacitance termination at the field device). Operation in the event of disturbance variables as per NAMUR NE21 is thus guaranteed.

#### NOTICE

**If the shielding of the cable is grounded at more than one point in systems without potential matching, power supply frequency equalizing currents can occur that damage the signal cable or have a serious effect on signal transmission.**

- ▶ In such cases the shielding of the signal cable is to be grounded on one side only, i.e. it must not be connected to the ground terminal of the housing. The shield that is not connected should be insulated!

## 5.6 Connecting to functional grounding

### 5.6.1 Panel-mounted device

For EMC reasons the functional grounding should always be connected. When the device is used in explosion hazardous environment (with optional Ex approval) the connection is obligatory.

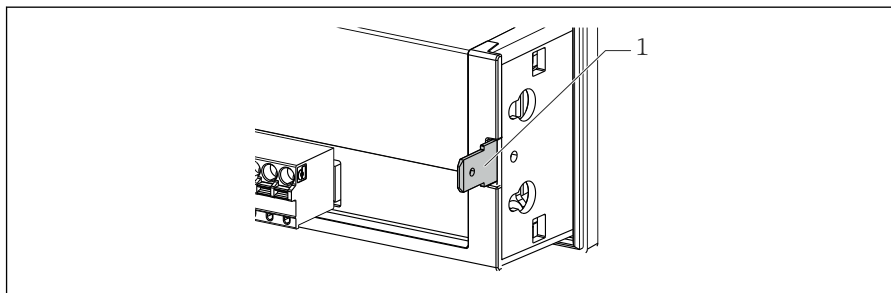

A0018894

 8 Functional grounding terminal on panel-mounted device

### 5.6.2 Field device

For EMC reasons the functional grounding should always be connected. When the device is used in explosion hazardous environment (with optional Ex approval) the connection is obligatory and the field housing must additionally be grounded via a grounding screw fitted on the outside of the housing.

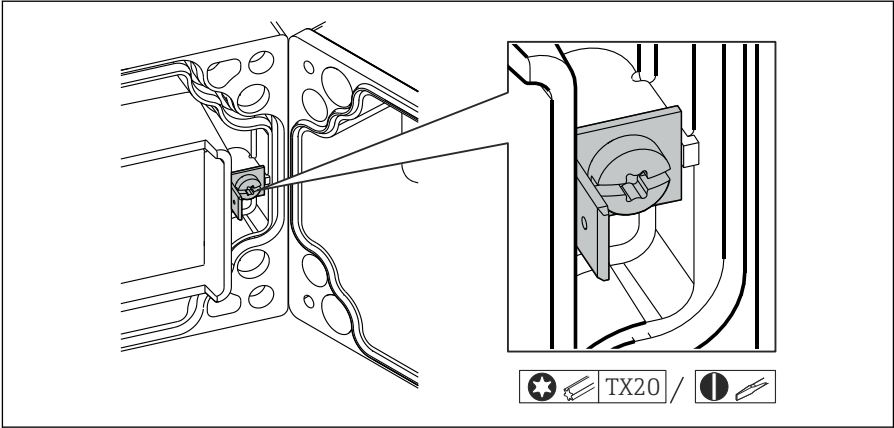

9 Functional grounding terminal in field housing

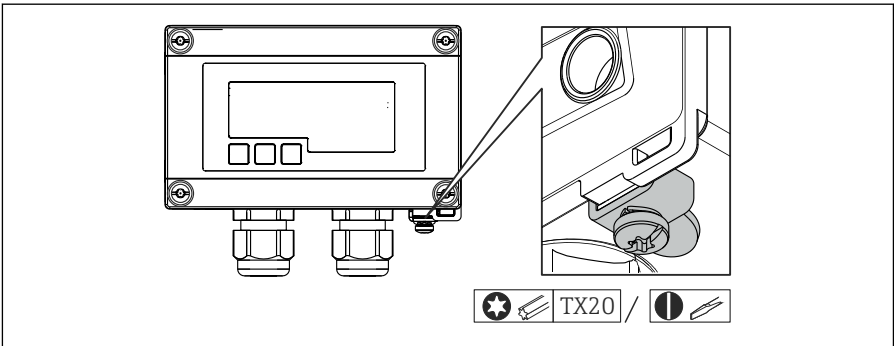

10 Ground terminal on field housing

## 5.7 Degree of protection

### 5.7.1 Field housing

The devices meet all the requirements of IP66. It is absolutely essential to comply with the following points to ensure this protection is guaranteed after mounting or servicing the device:

- The housing seal must be clean and undamaged when inserted into the groove. The seal must be cleaned, dried or replaced if necessary.
- The cables used for connection must be of the specified outside diameter (e.g. M16 x 1.5, cable diameter 5 to 10 mm (0.2 to 0.39 in)).
- Mount the measuring device in such a way that the cable entries point downwards.
- Replace unused cable entries with dummy plugs.
- The housing cover and the cable entries must be firmly tightened.



### 5.7.2 Panel housing

The front of the device meets the requirements of IP65. It is absolutely essential to comply with the following points to ensure this protection is guaranteed after mounting or servicing the device:

- The seal between the front of the housing and the panel must be clean and undamaged. The seal must be cleaned, dried or replaced if necessary.
- The threaded rods of the panel mounting clips must be firmly tightened.

## 5.8 Post-connection check

Device condition and specifications	Notes
Are cables or the device damaged?	Visual inspection
Electrical connection	Notes
Does the supply current match the specifications on the nameplate?	-
Are the mounted cables, incl. functional grounding, connected correctly and strain-relieved?	-
Field housing: Are the cable glands securely closed?	-

## 6 Operation

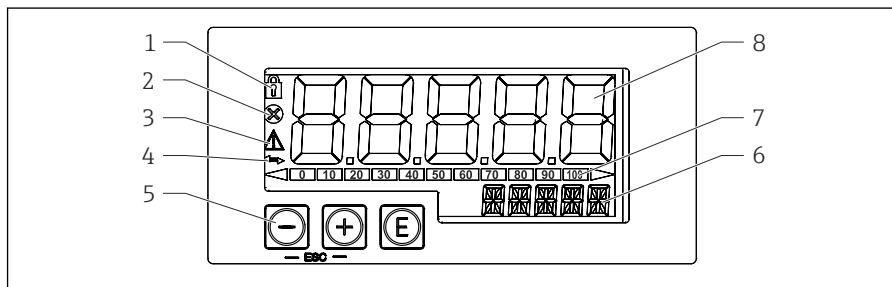



A0017719

11 Display and operating elements of the process display unit

- 1 Symbol: operating menu disabled
- 2 Symbol: error
- 3 Symbol: warning
- 4 Symbol: HART® communication active
- 5 Operating keys "-", "+", "E"
- 6 14-segment display for unit/TAG
- 7 Bar graph with indicators for under range and over range
- 8 5-digit 7-segment display for measured value, digit height 17 mm (0.67 in)

The device is operated using three operating keys on the front of the housing. The device setup can be disabled with a 4-digit user code. If the setup is disabled, a padlock symbol appears on the display when an operating parameter is selected.

 A0017716	Enter key; calling up the operating menu, confirming the option/setting parameters in the operating menu
 A0017714	Selecting and setting/changing values in the operating menu; pressing the '-' and '+' keys simultaneously takes the user back up a menu level. The configured value is not saved.
 A0017715	

### 6.1 Operating functions

The operating functions of the process display unit are divided into the following menus. The individual parameters and settings are described in the "Commissioning" section of the relevant Operating Instructions.

 If the operating menu is disabled by means of a user code, the individual menus and parameters can be displayed but not changed. To change a parameter, the user code must be entered. As the display unit can only display digits in the 7-segment display and not alphanumeric characters, the procedure for number parameters is different to that for text parameters.

If the operating position contains only numbers as parameters, the operating position is displayed in the 14-segment display and the configured parameter is displayed in the 7-segment display. To edit, press the 'E'-button followed by the user code.

If the operating position contains text parameters, only the operating position is initially displayed in the 14-segment display. If the 'E' button is pressed again, the configured parameter is displayed in the 14-segment display. To edit, press the '+' button followed by the user code.

<b>Setup (SETUP)</b>	Basic device settings
<b>Diagnostics (DIAG)</b>	Device information, display of error messages
<b>Expert (EXPERT)</b>	Expert settings for the device setup The Expert menu is protected from editing by an access code (default 0000).



